

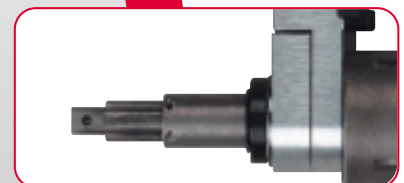

Pneumatic Torque Motors



Contents and Torque Motor Selection

Contents

Torque Motor Selection *page 2*

Torque Controlled Shut Off..... *page 4*

 SC Series..... *page 4*

 SD Series..... *page 6*

 F Series..... *page 8*

 Accessories *page 10*

System 100, Stall Torque *page 12*

 DM Series..... *page 12*

 HM Series..... *page 14*

 2HM5-HT Series. *page 16*

System 200/300, MTI/ITC..... *page 17*

Screwfeeding Systems..... *page 20*

Stands..... *page 21*

Slide Feed Units and Multiple Units... *page 22*









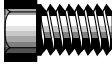

Other Assembly and Automation Products..... *page 23*

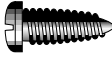
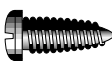
Torque Motor Selection

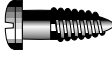
Criteria

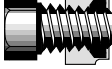
- Type of Fastener/Component
- Joint Integrity
- Torque Required

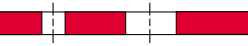
TYPE OF FASTENER/COMPONENT

Fastener/Component		Recommended Tool Type
Machine Screw/Nut		All Systems
Thread Rolling/Forming		All Systems
Self Tapping		System 100/200
Self Tapping in Plastic/Thin Materials		Torque Controlled Shut Off / HLT
Self Drilling		System 100/200
Wood Screws		System 100/200
Screws with Adhesive		System 300 with dual pressure control / HLT
Self Lock Nuts		System 300 with dual pressure control / HLT
Misaligned Holes		System 300 with dual pressure control / HLT
Variable Size Holes		System 300 with dual pressure control / HLT
Fragile Components		System 300 with 2 speed control / HLT

Torque Motor Selection

JOINT INTEGRITY

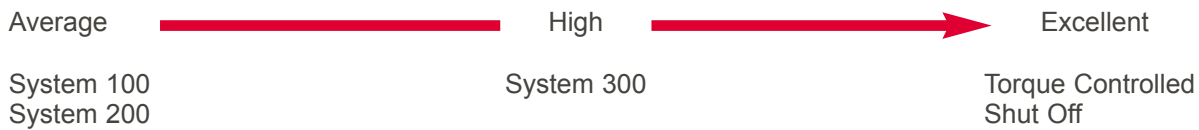

The Desoutter range of Torque Motors includes 4 options of torque control.

Torque Controlled Shut Off – 0.4-32Nm



These tools feature the Desoutter Target Tork clutch that operates a shut-off valve built into the tool. The low friction rolling action of the clutch dogs together with the synchronous air shut-off can provide torque repeatability's greater than $\pm 5\%$ depending on the joint.

System 100 – Stall Torque – 2-175Nm



With this system the motors are controlled by regulating the air pressure.

Stall torque is the best method of torque control for the majority of joints of a non critical nature and torque repeatability of $\pm 10\%$ can be readily achieved with a consistent air supply.

System 200 – Minimum Torque Indication (MTI) – 9-175Nm



System 200 is used where a signal is required to show that the minimum torque required has been achieved.

The motor is mounted on a caliper which incorporates a torque reaction spring of a known value. The fixed part of the caliper is bolted to the base plate of the unit whilst the motor is mounted onto the moving part of the caliper.

When the motor stalls out the caliper closes and provided the minimum torque has been achieved, closes a valve or switch. The signal can be used to provide a visual indication, signal a PLC or other ancillary equipment.

System 300 – Indicated Torque Control (ITC) – 9-175Nm

When more accurate control of torque is required, outside the scope of stall torque, some means of motor shut-off must be used so the motors can be stopped when the torque has been achieved. Desoutter System 300 is designed to shut-off the motors when the desired torque has been reached. It uses the same caliper system as System 200, but the signal from the caliper is used to switch a shuttle valve, controlling air entry into the motor. The signal from the valve can also be used to operate other equipment.

The ITC System is not subject to error due to air pressure fluctuation as motors can operate at higher pressure settings than would be used when operating the motor under stall conditions. This also means that faster cycle times can be achieved.

Torque Controlled Shut Off – SC Series

A

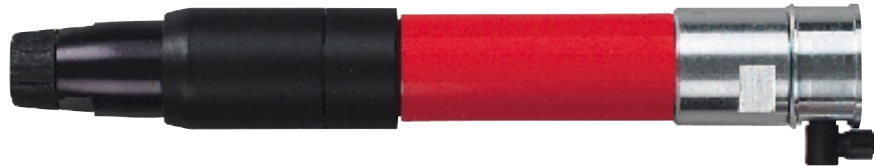

PUSH START – SHUT OFF – ONE WAY

PICTURE REF	TOOL TYPE	PART NUMBER	FREE SPEED	TORQUE RANGE	FITTED SPRING	AIR FLOW	AIR HOSE BORE	AIR INLET	SOUND LEVEL	VIBRATION
			r/min	Nm	Nm	l/s	mm	BSP	dB(A)	ms ⁻²
A	ASPC021-1A2300-S4Q	1458774	2300	0.4-2.1	0.4-0.9	7	6	1/8"	75	<2.5
A	ASPC021-1A1600-S4Q	1458784	1600	0.4-2.9	0.6-2.1	7	6	1/8"	75	<2.5
A	ASPC043-1A1100-S4Q	1458794	1100	0.4-4.2	0.9-4.2	7	6	1/8"	75	<2.5
A	ASPC047-1A550-S4Q	1458804	550	0.4-4.5	0.9-4.5	7	6	1/8"	75	<2.5

REMOTE START – SHUT OFF – TWO WAY

PICTURE REF	TOOL TYPE	PART NUMBER	FREE SPEED	TORQUE RANGE	FITTED SPRING	AIR FLOW	AIR HOSE BORE	AIR INLET	SOUND LEVEL	VIBRATION
			r/min	Nm	Nm	l/s	mm	BSP	dB(A)	ms ⁻²
A	ASPC021-2A2300-S4Q	1458814	2300	0.4-2.1	0.4-0.9	7	6	1/8"	75	<2.5
A	ASPC021-2A1600-S4Q	1458824	1600	0.4-3.0	0.6-2.1	7	6	1/8"	75	<2.5
A	ASPC043-2A1100-S4Q	1458834	1100	0.4-4.3	0.9-4.3	7	6	1/8"	75	<2.5
A	ASPC047-2A550-S4Q	1458844	550	0.4-4.5	1.0-4.5	7	6	1/8"	75	<2.5

Pneumatic Control

Remote start tools will start as soon as air is supplied to the forward or reverse port.

Pressure tapping gives a 3 bar signal while tool is running. Signal stops when the clutch operates.

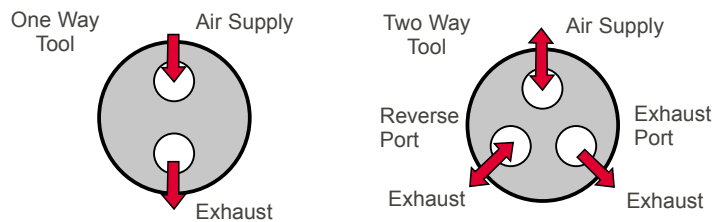

Torque Range and Spring Selection

To obtain the torque required the clutch spring may have to be changed. There are 3 spring types, white, black and natural. The torque ranges are shown in the table below:

SPRING	TORQUE RANGE	TOOL TYPES
	Nm	
White	0.4-0.9	All Models
Black	0.6-2.0	ASPC047
	0.6-2.1	ASPC021
	0.6-2.2	ASPC043
Natural	1.0-2.9	ASPC021-1A1600
	1.0-3.0	ASPC021-2A1600
	0.9-4.2	ASPC043-1A1100
	0.9-4.3	ASPC043-2A1100
	0.9-4.5	ASPC047-1A550
	1.0-4.5	ASPC047-2A550

SC Series – Dimensions

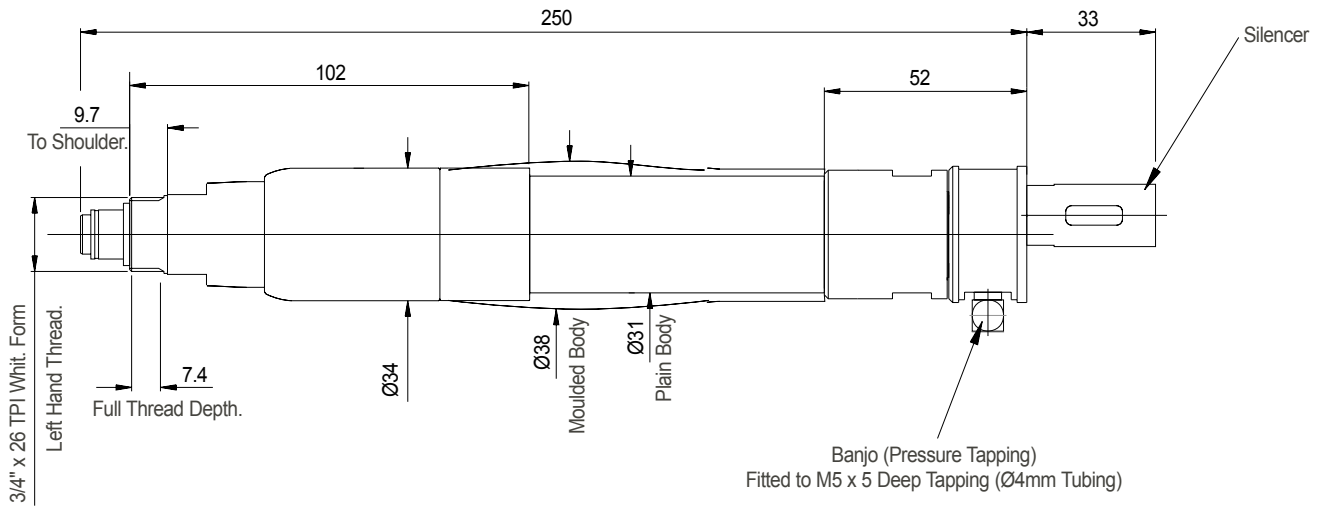

1 Way tool Only Is Offered With Either Moulded Or Plain Motor Case

Weight 0.68kg

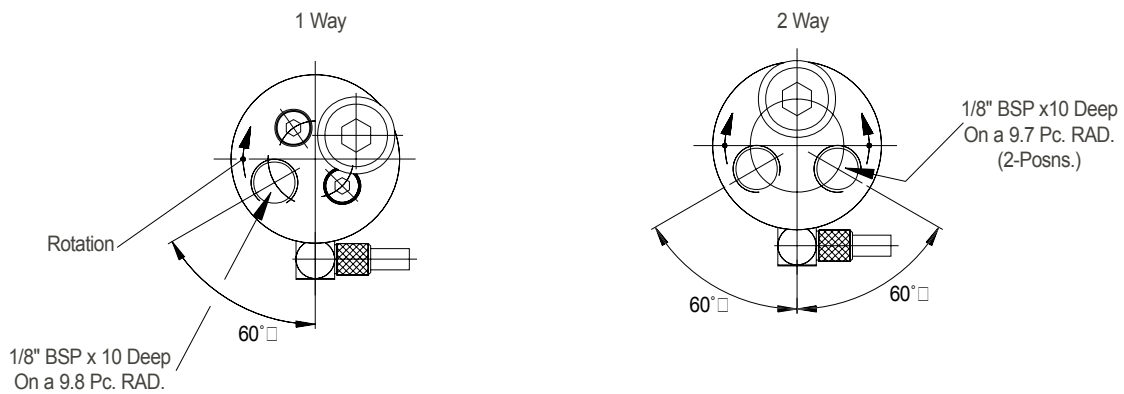

Torque Controlled Shut Off – SD Series

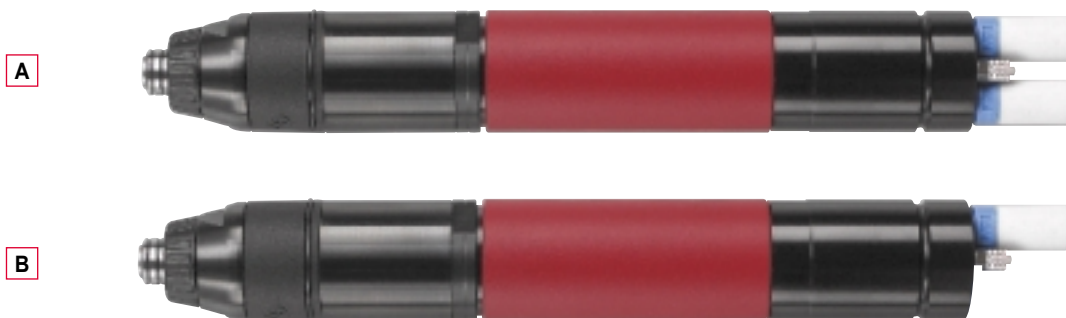

PUSH START – SHUT OFF – ONE WAY

PICTURE REF	TOOL TYPE	PART NUMBER	FREE SPEED	TORQUE RANGE	FITTED SPRING	AIR FLOW	AIR HOSE BORE	AIR INLET	SOUND LEVEL	VIBRATION
			r/min	Nm	Nm	l/s	mm	BSP	dB(A)	ms ²
A	SD023-1AM3500-S4Q	1464254	3500	1.0-2.3	1.0-2.3	8.7	6	1/8"	73	<2.5
A	SD035-1AM2200-S4Q	1464244	2200	1.0-3.5	1.0-3.5	8.7	6	1/8"	73	<2.5
A	SD055-1AM1470-S4Q	1464234	1470	2.0-5.5	2.0-5.5	8.7	6	1/8"	73	<2.5
A	SD075-1AM1100-S4Q	1464224	1100	2.5-7.5	2.5-7.5	8.7	6	1/8"	73	<2.5
A	SD100-1AM820-S4Q	1464214	820	3.5-10	3.5-10	8.7	6	1/8"	73	<2.5
A	SD140-1AM510-S4Q	1464204	510	3.5-14	3.5-10	8.7	6	1/8"	73	<2.5
A	SD160-1AM320-S4Q	1464194	320	3.5-16	3.5-10	8.7	6	1/8"	73	<2.5

REMOTE START – SHUT OFF – TWO WAY

PICTURE REF	TOOL TYPE	PART NUMBER	FREE SPEED	TORQUE RANGE	FITTED SPRING	AIR FLOW	AIR HOSE BORE	AIR INLET	SOUND LEVEL	VIBRATION
			r/min	Nm	Nm	l/s	mm	BSP	dB(A)	ms ²
B	SD023-2RM3500-S4Q	1464324	3500	1.0-2.3	1.0-2.3	8.7	6	1/8"	73	<2.5
B	SD035-2RM2200-S4Q	1464314	2200	1.0-3.5	1.0-3.5	8.7	6	1/8"	73	<2.5
B	SD055-2RM1470-S4Q	1464304	1470	2.0-5.5	2.0-5.5	8.7	6	1/8"	73	<2.5
B	SD075-2RM1100-S4Q	1464294	1100	2.5-7.5	2.5-7.5	8.7	6	1/8"	73	<2.5
B	SD100-2RM820-S4Q	1464284	820	3.5-10	3.5-10	8.7	6	1/8"	73	<2.5
B	SD140-2RM510-S4Q	1464274	510	3.5-14	3.5-10	8.7	6	1/8"	73	<2.5
B	SD160-2RM320-S4Q	1464264	320	3.5-16	3.5-10	8.7	6	1/8"	73	<2.5

Pneumatic Control

Both tools produce signals for interfacing with other equipment.

M5 Port provides signal while tool is running. The signal stops when the clutch operates.



Torque Range and Spring Selection

The majority of the SD Series uses one spring to cover the entire torque range. The 320 and 510 r/min tools use two springs as per below.

SPRING	TOOL SPEED	
	510	320
465763	3.5-10	3.5-10
465753	7.5-14	7.5-16

SD Series – Dimensions

SD-1AM

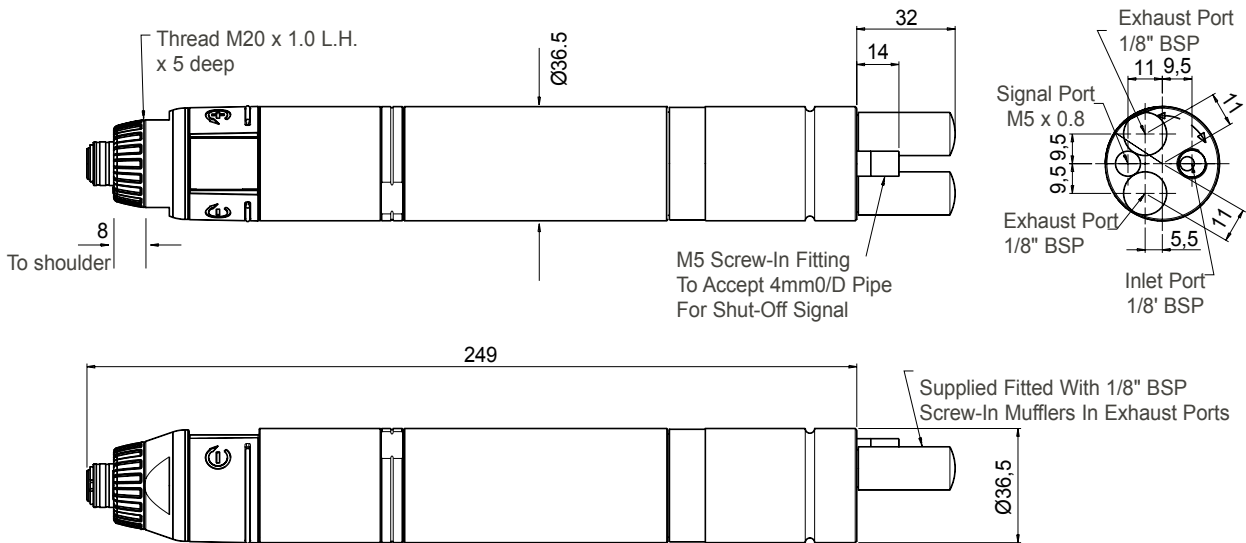

Weights

1AM (320, 510, 820, 1100 & 1470rpm) = 0.92kg

1AM (2200 & 3500 rpm) = 0.76kg

SD-2RM

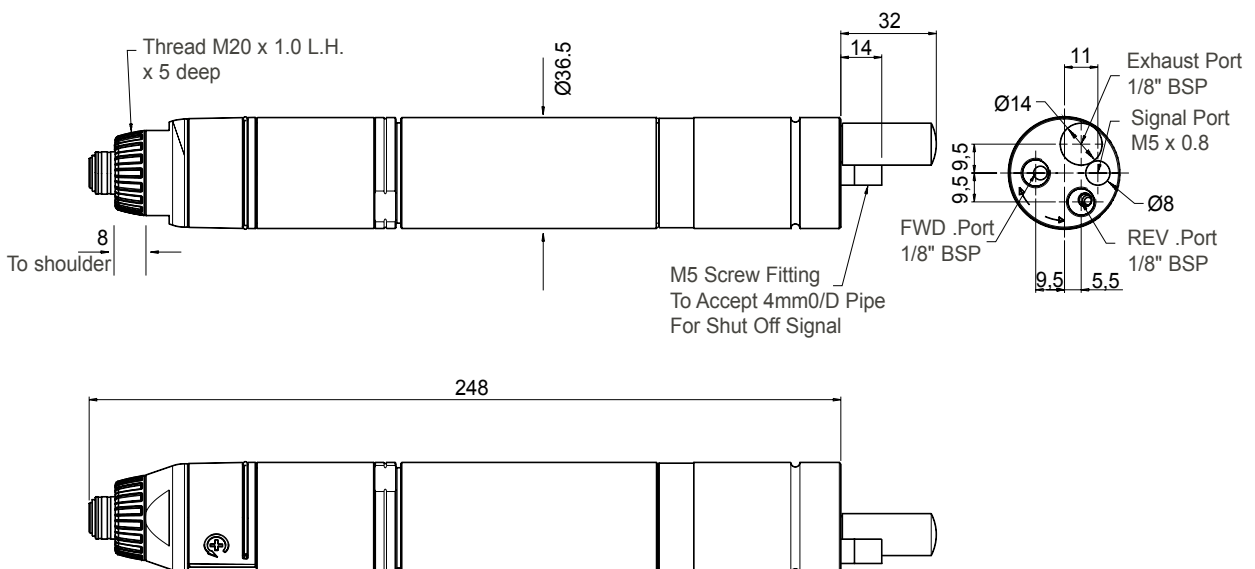

Weights

2RM (320, 510, 820, 1100 & 1470rpm) = 0.92kg

2RM (2200 & 3500 rpm) = 0.76kg

Torque Controlled Shut Off – F Series

A



B



PUSH START – SHUT OFF – MANUAL REVERSE

PICTURE REF	TOOL TYPE	PART NUMBER	FREE SPEED	TORQUE RANGE	FITTED SPRING	AIR FLOW	AIR HOSE BORE	AIR INLET	SOUND LEVEL	VIBRATION
			r/min	Nm	Nm	l/s	mm	BSP	dB(A)	ms ⁻²
A	2F89-AX-900	1462594	900	2.8-8.5	2.8-8.5	10	10	1/4"	76	<2.5
A	2F89-AX-630	1462584	630	3.5-12.0	3.5-12.0	10	10	1/4"	76	<2.5
B	2F89-AX-260	1462574	260	10.5-32.0	22.0-32.0	10	10	1/4"	76	<2.5

Outputs – 630/900rpm, 1/4" hex
 – 260rpm, 3/8" square

Pneumatic Control

The 2F89 tools produce a signal while the tool is running for interfacing with other equipment. The signal stops when the clutch operates.

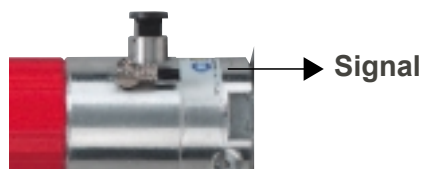

F Series – Dimensions

2F89-AX-630/900

900 r/min

7/8" .26.LH BSW x7.0

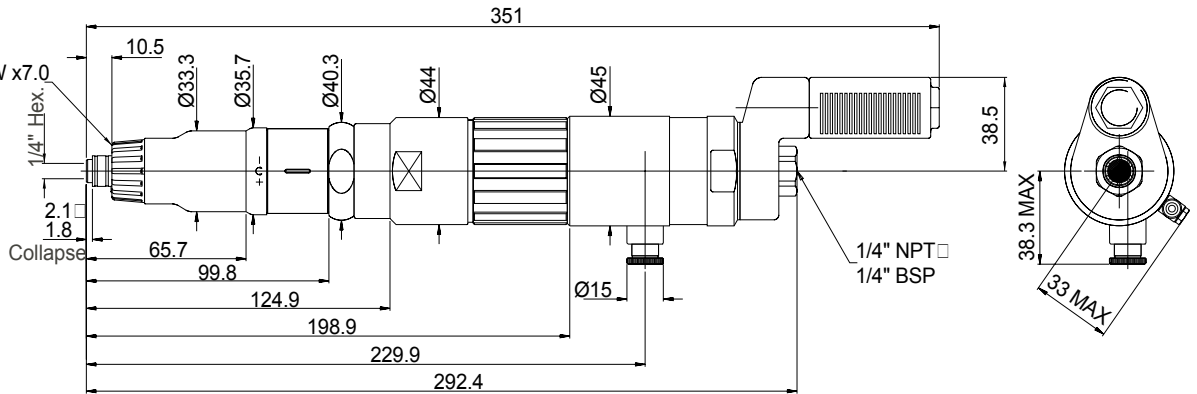

630 r/min

7/8" .26.LH BSW x7.0

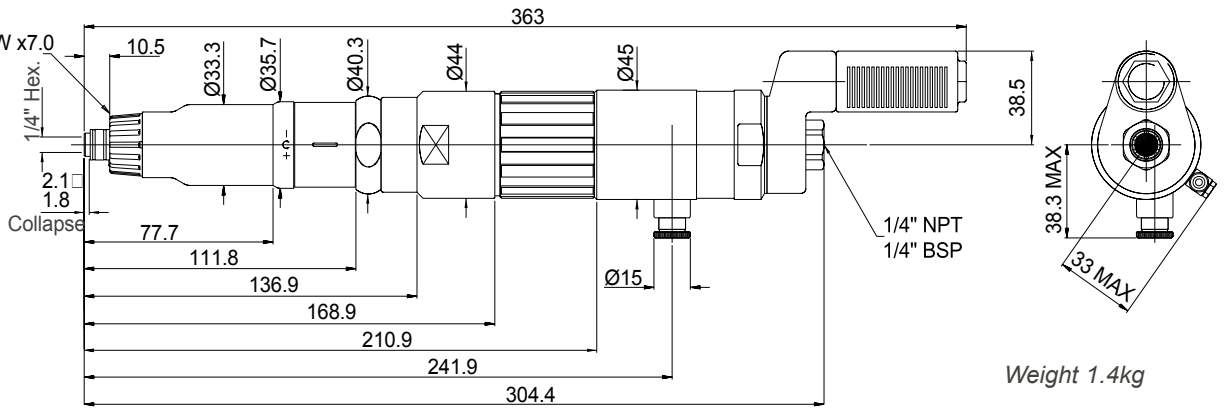



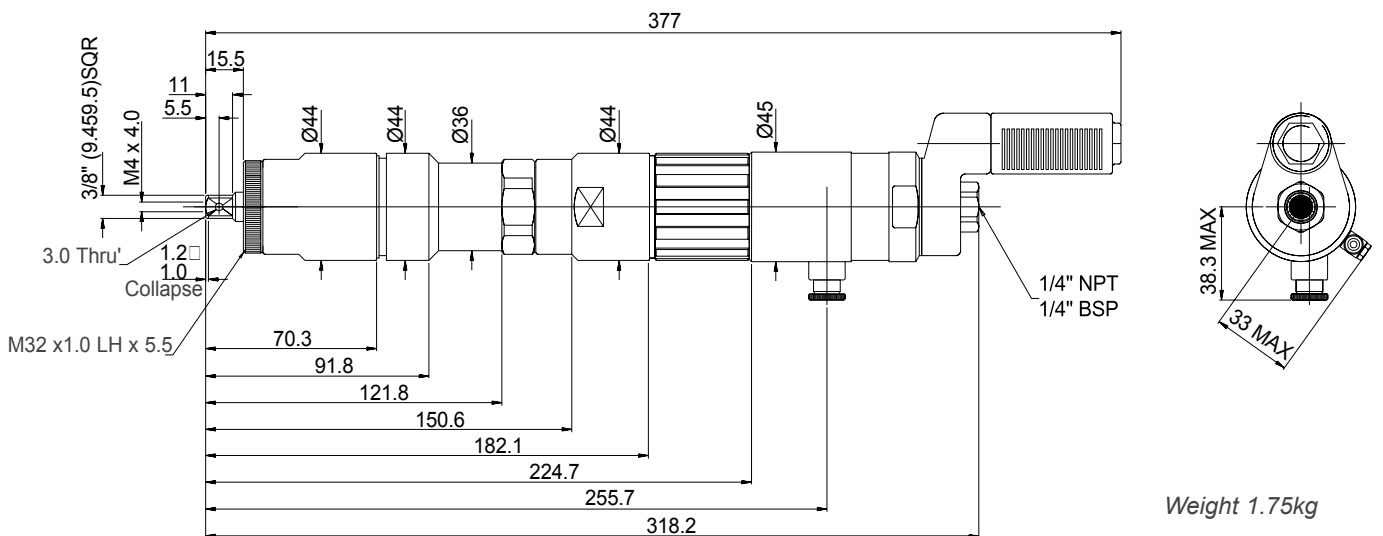

Weight 1.4kg

2F89-AX-260

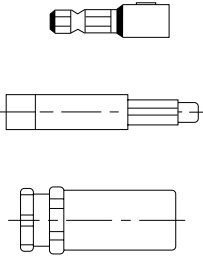

Weight 1.75kg

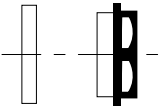
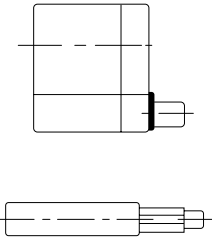
Torque Controlled Shut Off – Accessories

Accessories	ITEM	SC SERIES	SD SERIES	F SERIES
<p>Spring Loaded Shafts and Bearing Supports</p>  <p>Provides a rigid output drive and mounting for use in single or multi spindle assembly units.</p>		<p>103782</p> <p>108342</p> <p>103742</p>	<p>103782</p> <p>108342</p> <p>108412</p>	<p>103782</p> <p>108342</p> <p>103752</p>
<p>Nose Mounts</p>  <p>Mounting to allow torque motors to be mounted squarely on a plate (not required if a bearing support is used).</p>		<p>103722</p>	<p>108392</p>	<p>103732</p>
<p>Offset Heads</p>  <p>Offset head and output spindle for applications with close centres (minimum 19mm).</p>		<p>384993</p> <p>108352</p>	<p>384993</p> <p>108352</p>	<p>–</p> <p>–</p>
<p>Screwdriver Bit Adaptor</p>  <p>Quick release bit adaptor for use with the output shafts above. Provides a 1/4" hex output.</p>		<p>108322</p>	<p>108322</p>	<p>108322</p>

Torque Controlled Shut Off – Accessories

108342/
108352

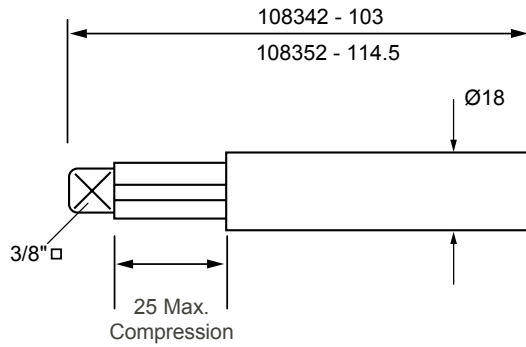

130742/108412

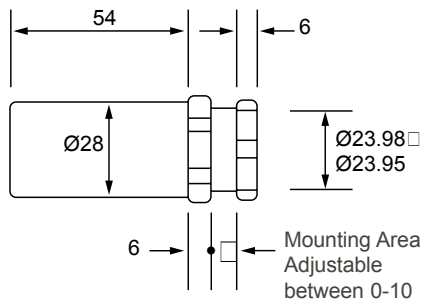

103752

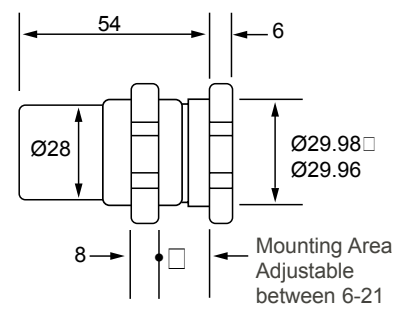

384993

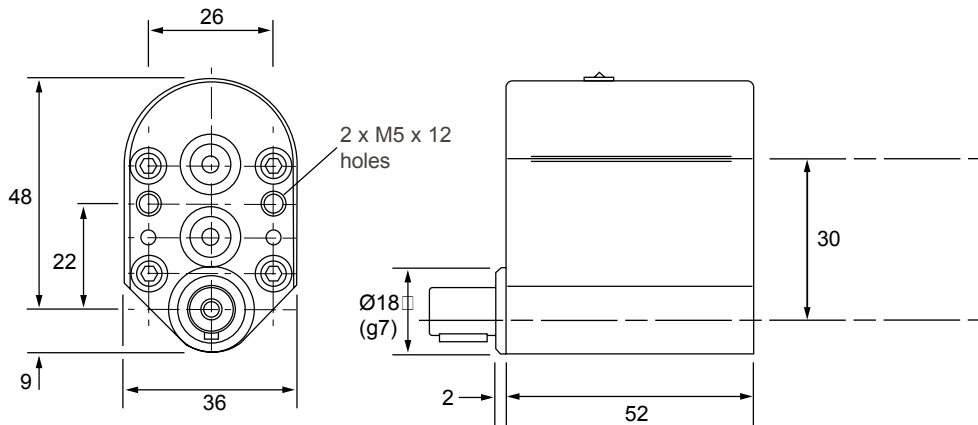

103722/103732/108392

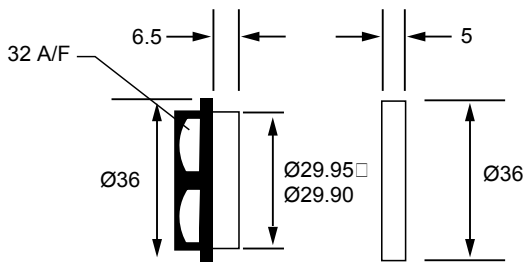

108322

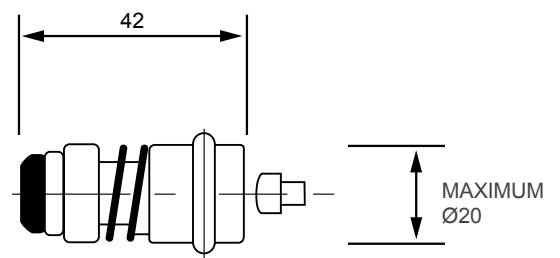

System 100 – DM Series

A



B



SPECIFICATION

PIC REF	TOOL TYPE	MOTOR ROTATION	AIR FLOW AT 6.3 BAR	AIR HOSE BORE	SOUND LEVEL	VIBRATION
			l/s	mm	dB(A)	ms ⁻²
A	DM6	One Way	9.4	10	76	<2.5
B	2DM6	Two Way	9.4	10	73	<2.5

TORQUES

AIR PRESSURE		FREE SPEED				
bar	psi	290	390	620	980	1650
6	87	–	–	–	10.4	6.1
5	75	–	–	–	8.7	5.1
4	58	–	–	11.5	7.0	4.1
3	43	–	12	8.3	5.3	3.0
2	29	9	8	5.5	3.5	2.0

Maximum stall torque 12Nm

Data obtained from a lubricated air line

Torque figures are to be used as a guide only

Pneumatic Control

Tools will start as soon as air is supplied to the forward or reverse port.

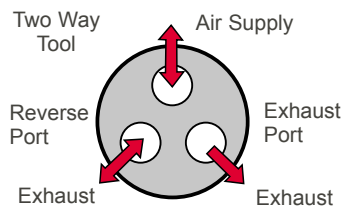

HOW TO ORDER

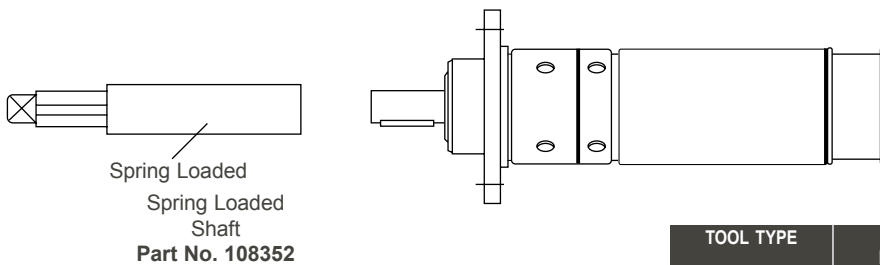

Flange for DM6 – **Part No. 441653** provides same mounting dimensions as 2DM6

TOOL TYPE	PART NUMBER	TOOL TYPE	PART NUMBER
DM6-290T	1454214	2DM6-290	1414164
DM6-390T	1454204	2DM6-390	1414244
DM6-620T	1454194	2DM6-620	1413774
DM6-980T	1454184	2DM6-980	1414084
DM6-1650T	1454304	2DM6-1650	1416604

System 100 – HM Series



REMOTE START – TWO WAY SPECIFICATION

PIC REF	TOOL TYPE	AIR FLOW AT 6.3 BAR	AIR HOSE BORE	SOUND LEVEL	SOUND POWER LEVEL	VIBRATION
		l/s	mm	dB(A)	dB(A)	ms ⁻²
A	2HM5	16.5	10	89	100	<2.5
B	2HM5 with Offset Head	16.5	10	89	100	<2.5

REMOTE START – TWO WAY TORQUES

AIR PRESSURE		FREE SPEED			
bar	psi	150	350	550	950
6	87	–	–	41	25
5	75	–	50	33	21
4	58	–	40	26	16
3	43	–	30	20	12
2	29	50	21	14	9

Maximum stall torque 51Nm
 Data obtained from a lubricated air line
 Torque figures are to be used as a guide only

Pneumatic Control

Tools will start as soon as air is supplied to the forward or reverse port.

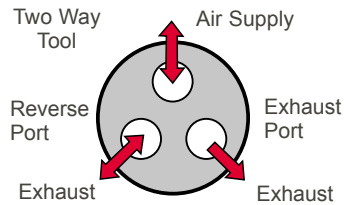

HOW TO ORDER

2DM6

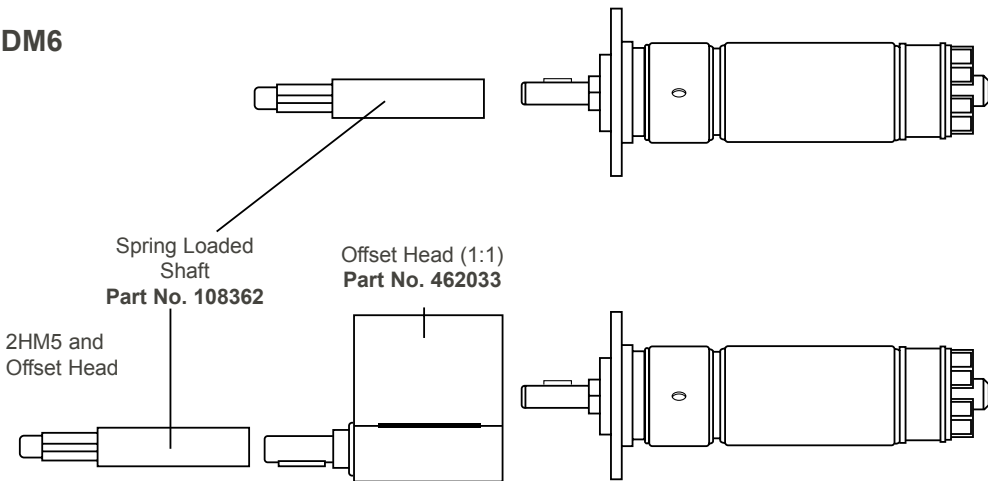

TOOL TYPE	PART NUMBER
2HM5-150	1309284
2HM5-350	1309444
2HM5-550	1309524
2HM5-950	1309604

HM Series – Dimensions

2HM5

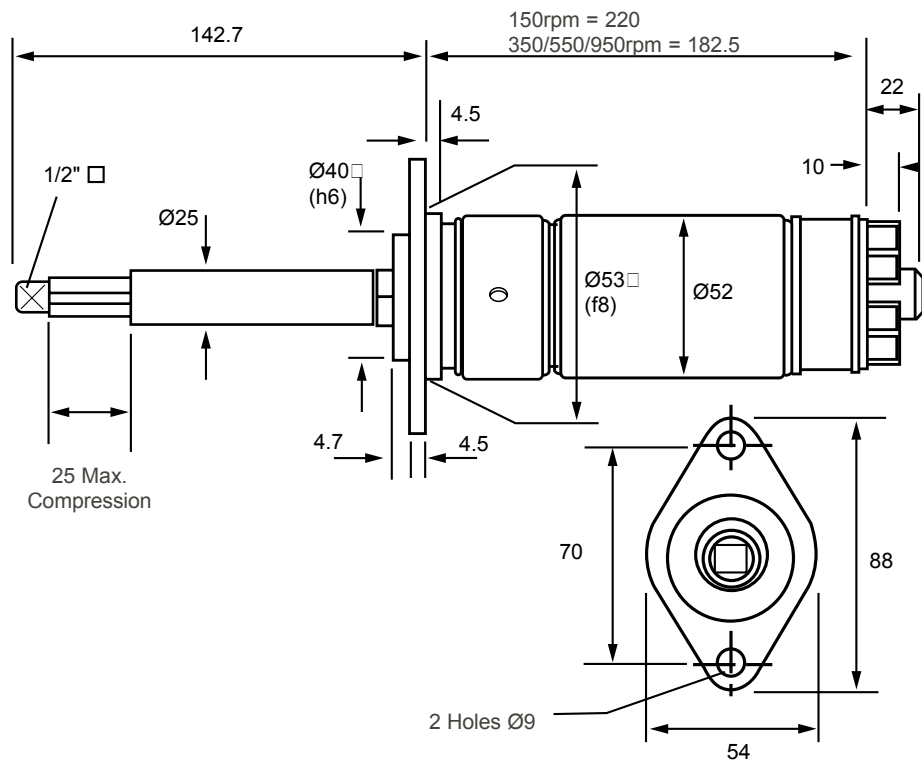

2HM5 and Offset Head

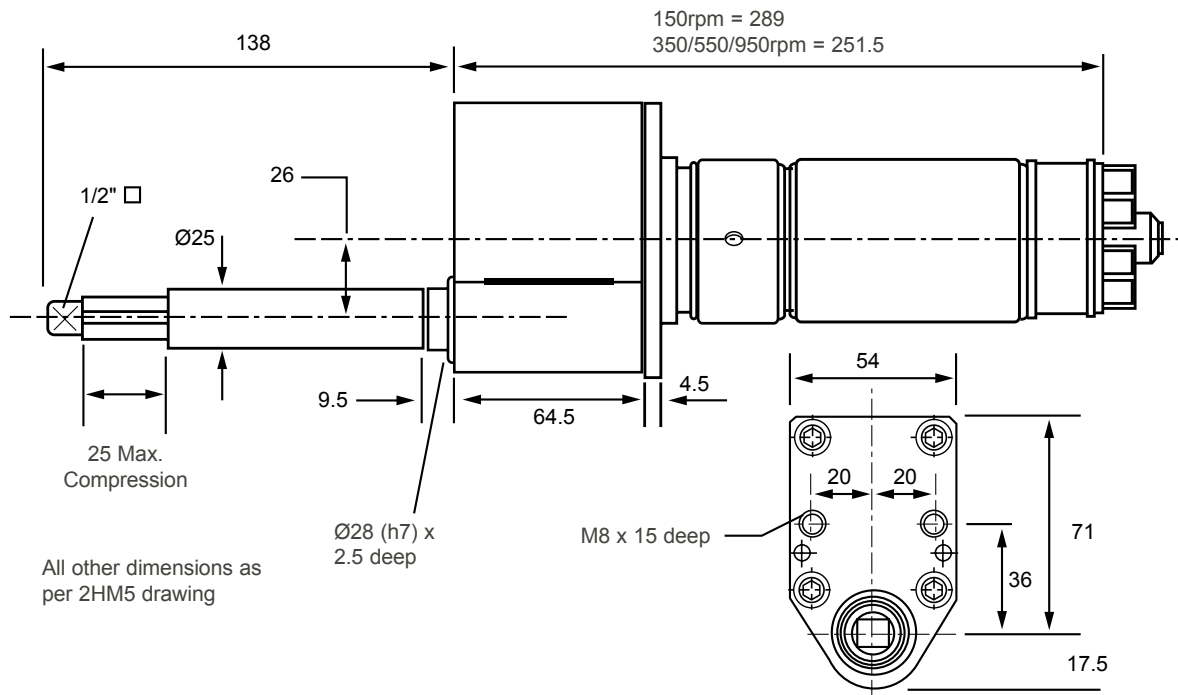

System 100 – 2HM5-HT Series

A



REMOTE START – TWO WAY

PICTURE REF	TOOL TYPE	PART NUMBER	FREE SPEED ⁽¹⁾	TORQUE RANGE	AIR FLOW ⁽¹⁾	AIR HOSE BORE	AIR INLET	SOUND LEVEL	SOUND POWER LEVEL	VIBRATION
			r/min	Nm	l/s	mm	BSP	dB(A)	dB(A)	ms ⁻²
A	2HM5-HT-230	1462654	230	30-85	16.5	10	1/4"	89	100	<2.5
A	2HM5-HT-130	1462644	130	50-140	16.5	10	1/4"	89	100	<2.5
A	2HM5-HT-80	1462634	80	75-175	16.5	10	1/4"	89	100	<2.5

⁽¹⁾ Values taken at 6.3 bar inlet pressure

TORQUES

AIR PRESSURE		FREE SPEED		
bar	psi	80	130	230
6	87	–	140	85
5	75	170	115	70
4	58	135	90	55
3	43	100	70	45
2	29	75	50	30

Maximum stall torque 175Nm

Data obtained from a lubricated air line

Torque figures are to be used as a guide only

Pneumatic Control

Tools will start as soon as air is supplied to the forward or reverse port.

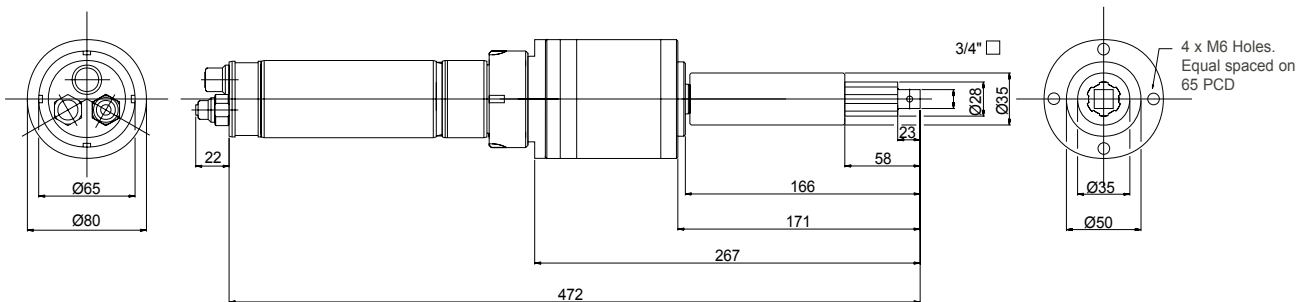
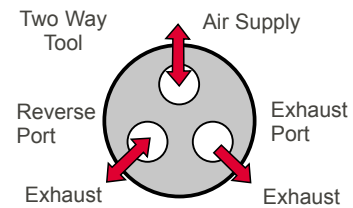

Collapsed View

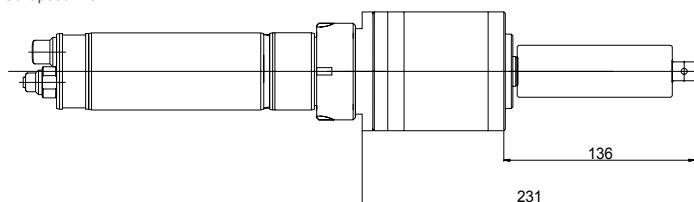

Weight 5.7kg

System 200/300 – 2HM5-MTI/ITC

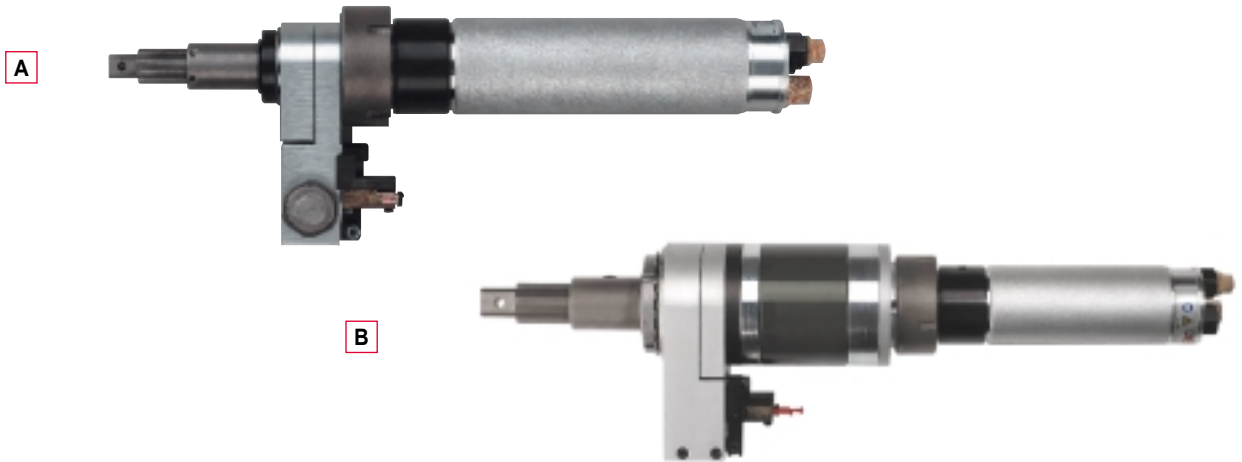

REMOTE START – ONE WAY

PICTURE REF	TOOL TYPE	PART NUMBER	FREE SPEED ⁽¹⁾	TORQUE RANGE	AIR FLOW ⁽¹⁾	AIR HOSE BORE	AIR INLET	SOUND LEVEL	SOUND POWER LEVEL	VIBRATION
			r/min	Nm	l/s	mm	BSP	dB(A)	dB(A)	ms ⁻²
A	2HM5-550-MTI/ITC	1462624	550	15-41	16.5	10	1/4"	89	100	<2.5
A	2HM5-350-MTI/ITC	1462614	350	21-51	16.5	10	1/4"	89	100	<2.5
A	2HM5-150-MTI/ITC	1462604	150	45-51	16.5	10	1/4"	89	100	<2.5
B	2HM5-HT-230-MTI/ITC	1462684	230	30-85	16.5	10	1/4"	89	100	<2.5
B	2HM5-HT-130-MTI/ITC	1462674	130	50-140	16.5	10	1/4"	89	100	<2.5
B	2HM5-HT-80-MTI/ITC	1462664	80	75-175	16.5	10	1/4"	89	100	<2.5

⁽¹⁾ Values taken at 6.3 bar inlet pressure

2HM5 TORQUES

AIR PRESSURE		FREE SPEED		
bar	psi	150	350	550
6	87	–	–	41
5	75	–	50	33
4	58	–	40	26
3	43	–	30	20
2	29	50	21	14

Maximum stall torque 51Nm

Data obtained from a lubricated air line
Torque figures are to be used as a guide only

2HM5-HT TORQUES

AIR PRESSURE		FREE SPEED		
bar	psi	80	130	230
6	87	–	140	85
5	75	170	115	70
4	58	135	90	55
3	43	100	70	45
2	29	75	50	30

Maximum stall torque 175Nm

HOW TO ORDER

PICTURE REF	SWITCH/VALVE	PART NUMBER
A	Pneumatic	108952
A	Electric	108962

PICTURE REF	TOOL TYPE	PART NUMBER
B	2HM5-550-MTI/ITC	1462624
B	2HM5-350-MTI/ITC	1462614
B	2HM5-150-MTI/ITC	1462604
B	2HM5-HT-230-MTI/ITC	1462684
B	2HM5-HT-130-MTI/ITC	1462674
B	2HM5-HT-80-MTI/ITC	1462664

System 200/300 – Control Circuits

SYSTEM 200

Indicating Light

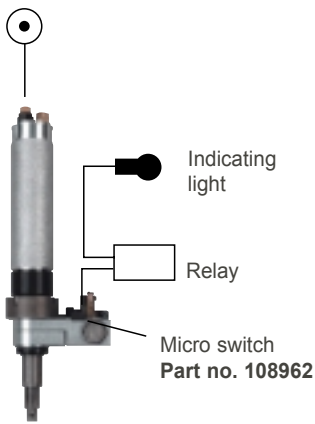

Pneumatic Indicator

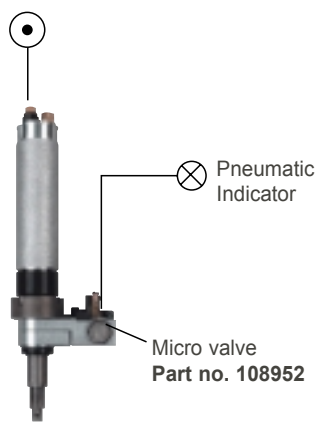

Signal to PLC

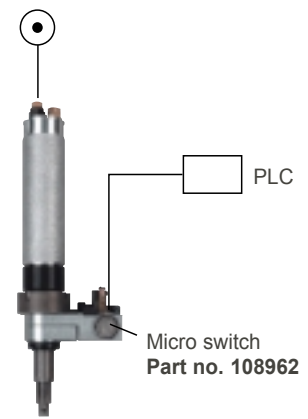

SYSTEM 300

Pneumatic Control

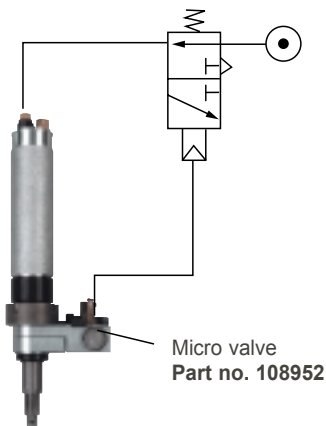

Electric Control

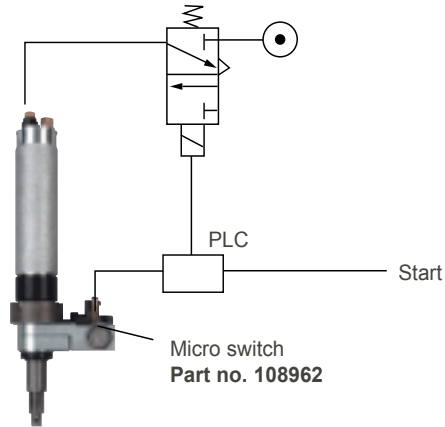

Electric Control with 2 Speed Cycle

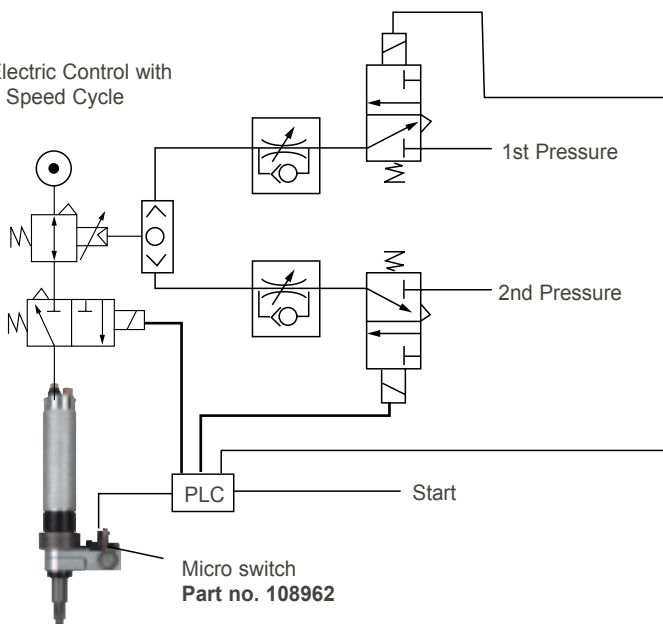

Notes:

- Ensure that any valves and tubing used with the torque motors have the appropriate air flow rating.
- Avoid using pneumatic lubricating oil in any control circuit.
- For high torques, it may be necessary to introduce a short pulse (<1 sec) of low pressure (<2 bar) air onto the reverse port to permit the socket to disengage from the fastener.

2HM5-MTI/ITC Series – Dimensions

2HM5-MTI/ITC

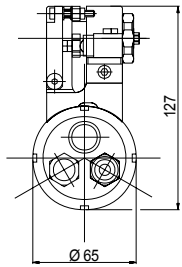

2HM5-350/550MTI/ITC

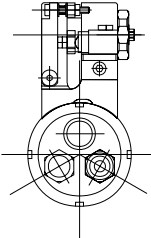
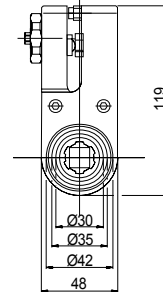
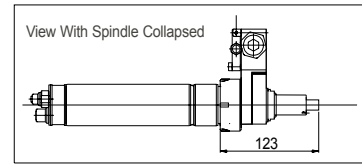
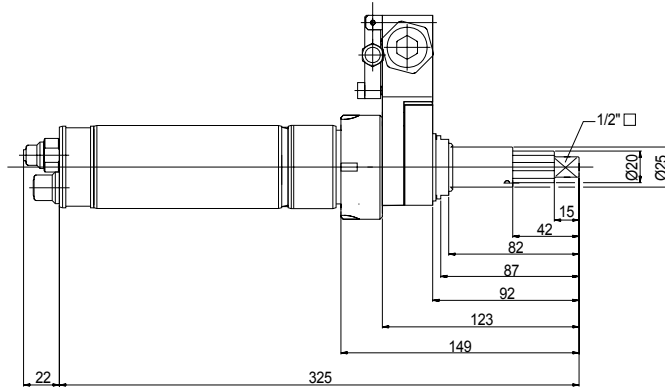

2HM5-150 MTI/ITC

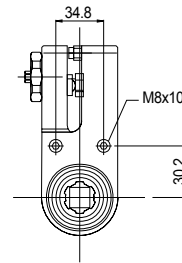
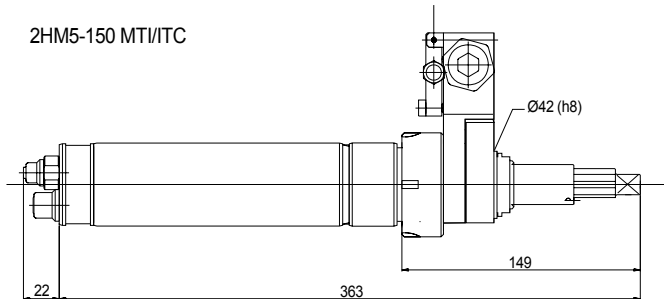

Weight 3.4kg

2HM5-HT-MTI/ITC

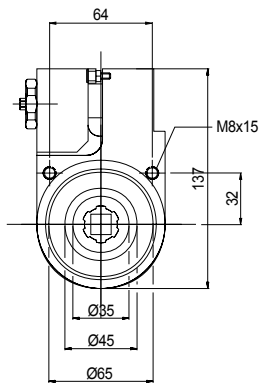
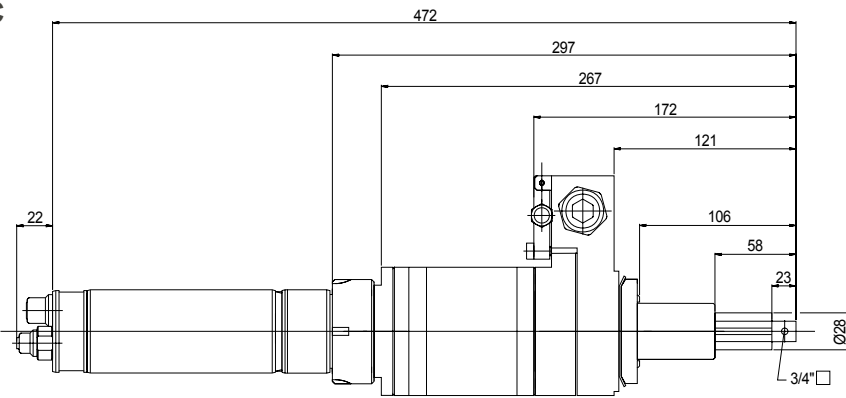
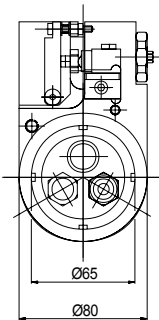

Collapsed View

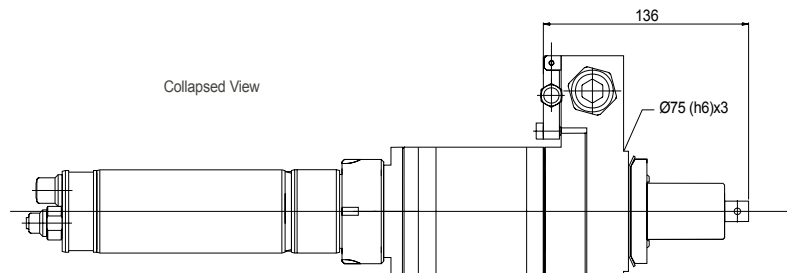

Weight 7.7kg

Screwfeeding Systems



For applications where productivity is of importance the use of a screwfeeder can dramatically reduce the fastening cycle time.

The range of Desoutter Screw Feeding Systems are capable of operation with hand operated and fixtured tools.

Ask for further details from your local sales contact.

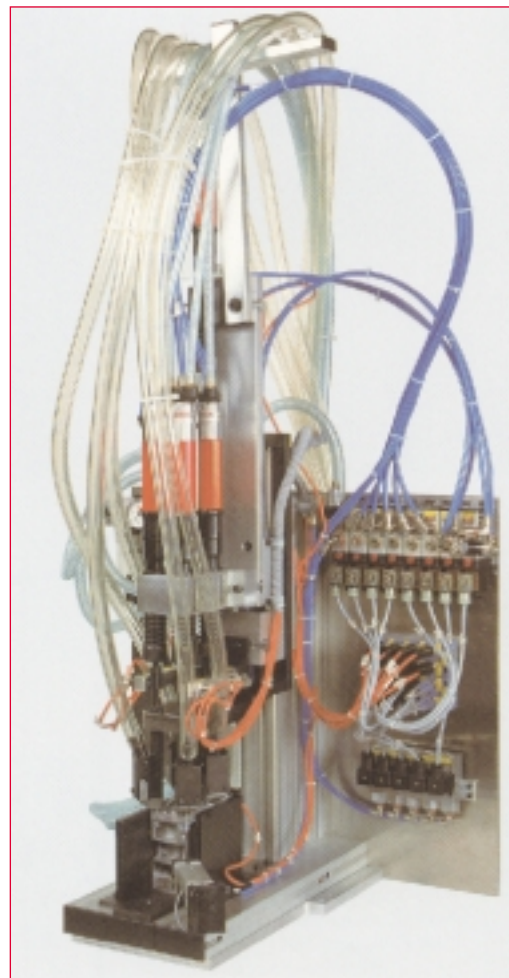

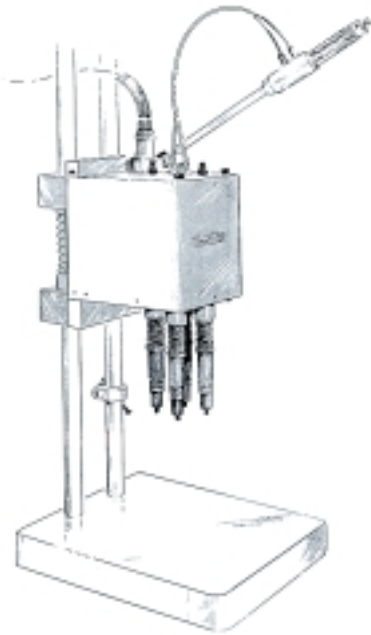

MC55 Cylinder-Operated Stand With Linear Bearings

Part No. 902914
Weight: 32 kg
Max. Stroke: 100mm
Max. Mounting Plate Load: 68 kg

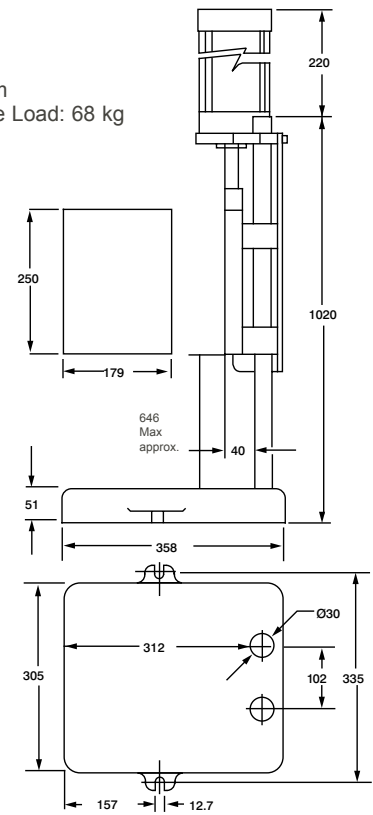

Lever operated version of the MC55 is available upon request.

Mounting Brackets can be made to order for the R55-S and MC55.

D54 Lever-Operated Stand For SD, DM6, 2DM6 Motors

Part No. 901944
Weight: 7 kg
Max. Stroke: 45mm

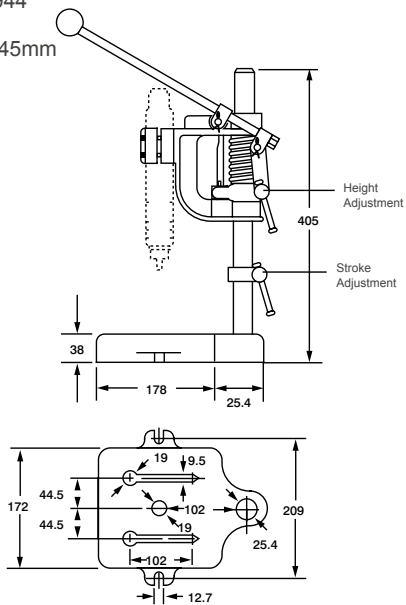

R55-S Lever-Operated Stand

Part No. 903644
Weight: 11.32 kg
Max. Stroke: 57mm
Max. Mounting Plate Load: 6 kg

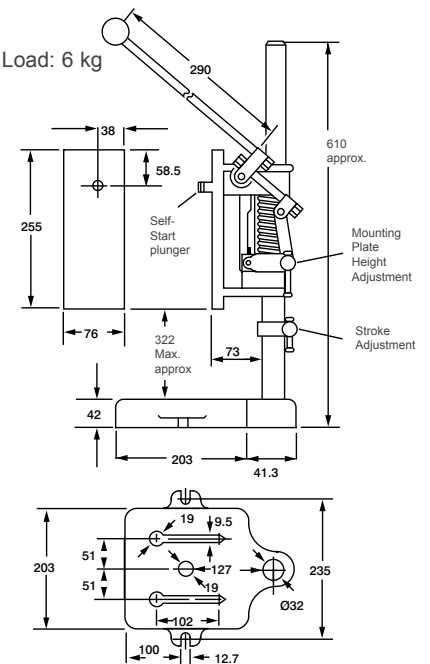

Slide Feed Units and Multiple Units

The Desoutter range also includes pneumatic slide feed units for automated assembly. The units can be manufactured to suit the application.

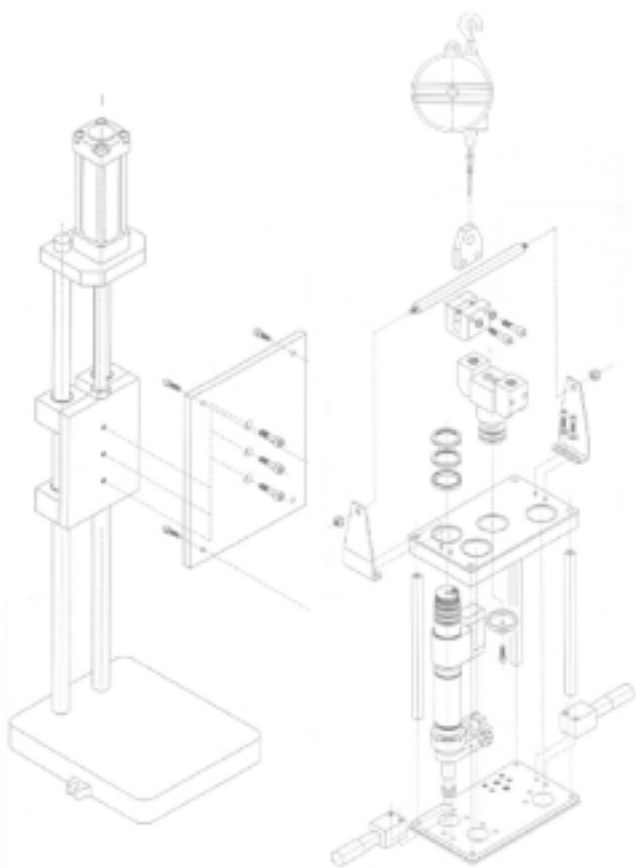
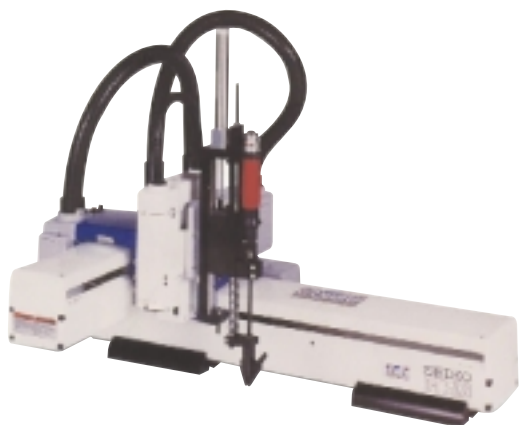

Desoutter can supply complete multiple spindle units to suit your application or supply kits of parts for assembly.

To discuss your assembly application please contact your local Desoutter technical support engineer.

Other Assembly and Automation Products

Fastening Tools



Assembly Systems

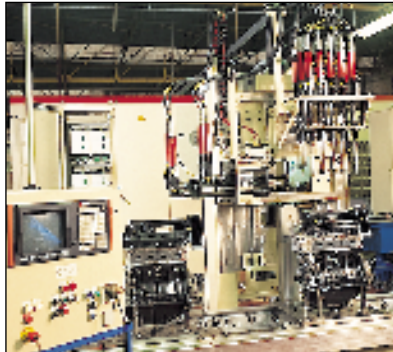

Electric Nutrunners

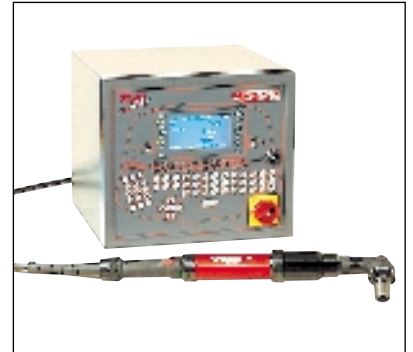

Installation Accessories



Auto Feed Drills and Tappers



Pneumatic Motors



General Safety Instructions for the Operation of Power Tools

The goal of Desoutter is to produce tools that help the operator work safely and efficiently.

The most important safety device for this or any other tool is the operator. Care and good judgement are the best protection against injury.

All possible hazards cannot be covered here, but we have tried to highlight some of the important ones.

Individuals should look for and obey Caution, Warning and Danger signs placed on tools, and displayed in the workplace. Operators should read and follow safety instructions packed with each tool. For a copy of these instructions, contact your local Desoutter representative.

Learn how each tool works. Even if you have previously used similar tools, carefully check out each tool before you use it. Get the 'feel' of it and know its capabilities, limitations, potential hazards, how it operates and how it stops.

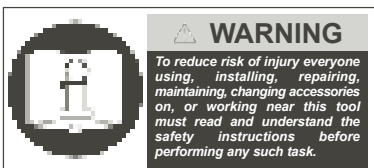

All tools are designed to operate at a line pressure of 6.3 bar +/- 0.15bar in accordance with ISO2787.

Sound levels +/- 3dB(A)* measured in accordance with CAGI-PNEUROP test code. Vibration values* measured in accordance with ISO 8662.

*These declared values were obtained by laboratory testing in compliance with stated standards and are not adequate for risk assessments. Values measured in individual work places may be higher than the declared values. The actual exposure values and risk of harm experienced by an individual are unique and depend upon the way the user works, the workpiece and the work station design, as well as upon the exposure time and the physical condition of the user. We Desoutter cannot be held liable for the consequences of using declared values, instead of values reflecting the actual exposure, in an individual risk assessment in a work place situation over which we have no control.

All product in this catalogue is classified as "machinery to be incorporated" in accordance with the European Machinery Directive.

Specifications subject to change without prior notice.

Further occupational health and safety information can be obtained from the following web sites
<http://www.osha.gov> (USA)
<http://europe.osha.eu.int> (Europe).



Compressed Air Hazards

- Air under pressure can cause injury. Never point an air hose at yourself or anyone else. Never blow your clothes free of dust with compressed air. Always direct exhaust air away from yourself and others in the work area.
- Always check for damaged or loose hoses and fittings before using an air tool, and replace if necessary. Whipping hoses can cause serious injury.
- Disconnect the tool from the air supply when not in use, before changing accessories, setting the torque, or when making repairs.
- Do not exceed rated air pressure to increase the output of the tool. This could cause injury and shorten tool life.
- Do not assemble quick coupler on the tool. Vibration can cause breakage resulting in a whipping air hose. Instead, use quick couplers on the end of a short leader hose.
- When universal twist couplings are used, lock pins must be installed to prevent accidental hose disconnection.
- Air tools are not intended for use in explosive atmospheres and are not insulated for contact with electric power sources.



Sales Contacts:

- **Asia, Australia, New Zealand, Japan**
telephone (852) 235 70 963
facsimile (852) 276 31 875
- **Austria**
telephone (43) 2246 4677
facsimile (43) 2246 4682
- **Belgium, Luxembourg**
telephone (32) 2 660 4938
facsimile (32) 2 672 6092
- **France**
telephone (33) 2 40 80 20 00
facsimile (33) 2 40 33 27 07
- **Germany**
telephone (49) 6181 4110
facsimile (49) 6181 411184
- **India**
telephone (91) 22 564 0011/21
facsimile (91) 22 568 3705
- **International**
telephone (44) 1442 344 300
facsimile (44) 1442 344 602
- **Italy**
telephone (39) 039 244 101
facsimile (39) 039 465 5025
- **Netherlands**
telephone (31) 765 878 668
facsimile (31) 765 878 825
- **Portugal**
telephone (35) 121 315 87 92
facsimile (35) 121 315 87 93
- **South Africa**
telephone (27) 11 821 9300
facsimile (27) 11 821 9360
- **Spain**
telephone (34) 91 590 3152
facsimile (34) 91 590 3161
- **United Kingdom**
telephone (44) 1442 344 301
facsimile (44) 1442 344 600
- **United States of America, Mexico, Canada**
telephone (1) 800 367 2442
facsimile (1) 800 232 6611

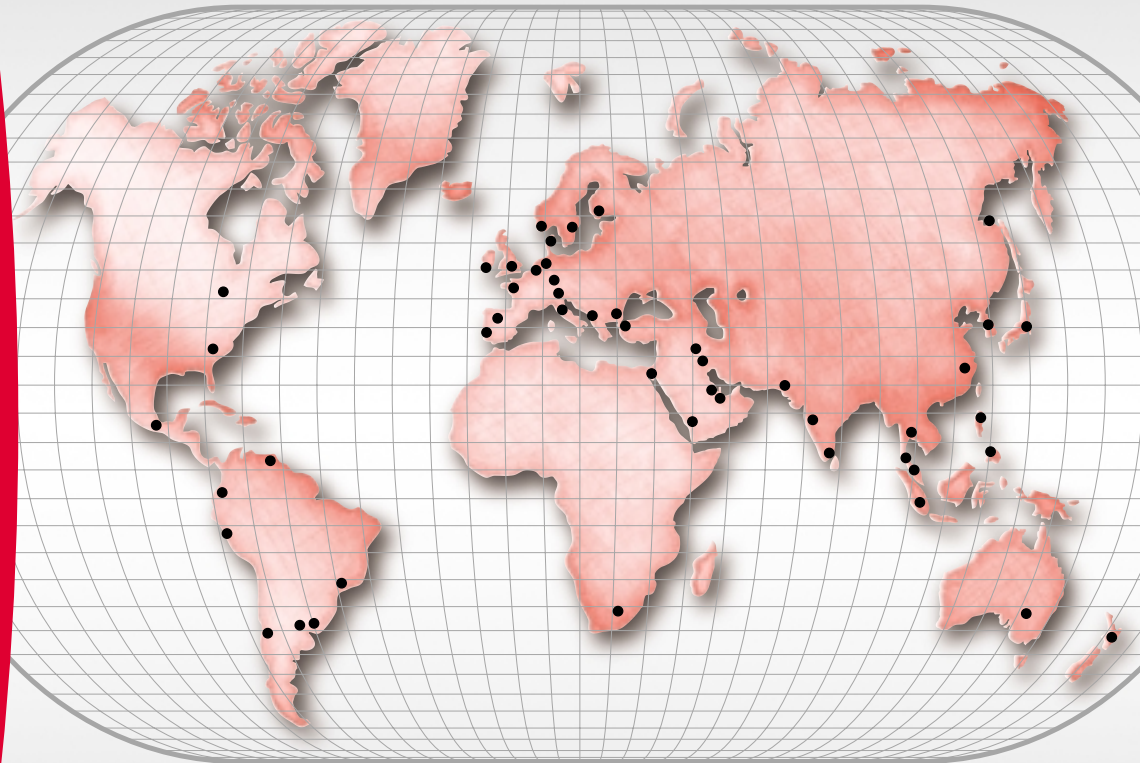

www.chicagopneumatic.com



Certificate No. FM28383
Desoutter Limited
ISO 9001 Registered